

**Product Information**

**NW1-020/025HM / K**

**Level Switch NW1**

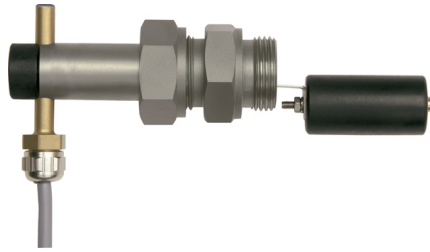

- Highly reproducible
- Normally open or normally closed contact

**Characteristics**

Mechanical level monitor for fluid media, with contact-free triggering of a reed contact.

**Technical data**

<b>Switch</b>	reed switch	
<b>Process connection</b>	male thread G 3/4 A; G 1 A	
<b>Density of medium</b>	Spansil float      □0.7 g/cm <sup>3</sup> Stainless steel float      □0.9 g/cm <sup>3</sup>	
<b>Pressure resistance</b>	Spansil float      PN 25 bar Stainless steel float      PN 10 bar PVDF float      PN 25 bar	
<b>Medium temperature</b>	-20..+110 °C (optional 150 °C)	
<b>Ambient temperature</b>	-20..+70 °C	
<b>Media</b>	water, oils	
<b>Wiring</b>	'normally open' or 'normally closed' No. 0.225	
<b>Switching voltage</b>	max. 230 V AC	
<b>Switching current</b>	max. 1 A	
<b>Switching capacity</b>	Max. 50 VA	
<b>Protection class</b>	1 - PE connection	
<b>Ingress protection</b>	IP 65	
<b>Electrical connection</b>	cable 1.5 m	
<b>Materials medium-contact</b>	<i>Brass construction:</i> CW614N nickelled, 1.4301, 1.4571, Spansil (NBR), Hard ferrite, NBR	<i>Stainless steel construction:</i> 1.4305, 1.4571, Hard ferrite, FKM
<b>Non-medium-contact materials</b>	CW614N, nickelled, CW614N, NBR, PVC, POM	
<b>Weight</b>	0.35 kg	
<b>Installation location</b>	horizontal installation	

**Dimensions**

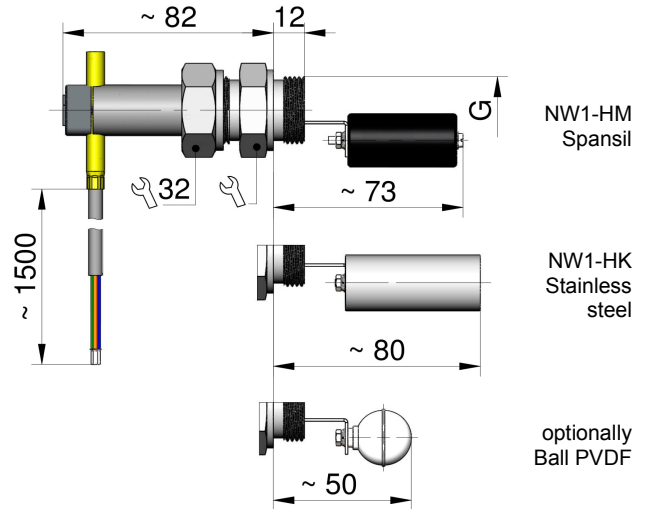

**Handling and operation**

- It must be ensured that the values given for voltage, current, and power are not exceeded.
- When switched on, a load must be connected in series.
- The electrical details apply to ohmic loads. Capacitive, inductive and lamp loads must be operated using a protective circuit.
- Not suitable for use in media with ferritic particles.
- Switch position is fixed at factory.

**Ordering code**

NW1 -  1.  2.  3.  4.  
 H

○=Option

<b>1. Connection size</b>		
020	threaded connection G 3/4 A	
025	threaded connection G 1 A	
<b>2. Process connection</b>		
H	screw-in thread	
<b>3. Connection material</b>		
M	brass	
K	stainless steel	
<b>4. Switching unit option</b>		
A	○ for switching unit ATEX A-U1-2 The switching unit must be ordered in addition.	

**Options**

- Float ball PVDF
- Float cylinder stainless steel